

2020

电气技术实践 综合设计展示

多功能电子秤

熊梓岑-18376372
宫晓睿-18375250
戴文博-18375472

目 录

CONTENTS

1

功 能 描 述

2

流程图及电路设计

3

Proteus模拟

4

电 路 组 装

5

实际电路测试调试

PART 01

功 能 描 述

电子秤功能描述

重量读取

采用应变片电桥采集，经运放放大后输入下一级

超重报警

为保证结构安全及输入限制，用比较器设置安全电压，超过则断开输入并报警

延时关机

采用555定时电路，规定时间内无信号输入则自动关机



模数转换&码制转换

使用模数转换模块与加法器，取合适的频率，使人眼看到无闪烁的数字。

去皮模块

使用存储器存储重量，减法器实现去皮操作

单价-总价显示

计数器与比较器级联反馈调节，通过累加实现乘法计算

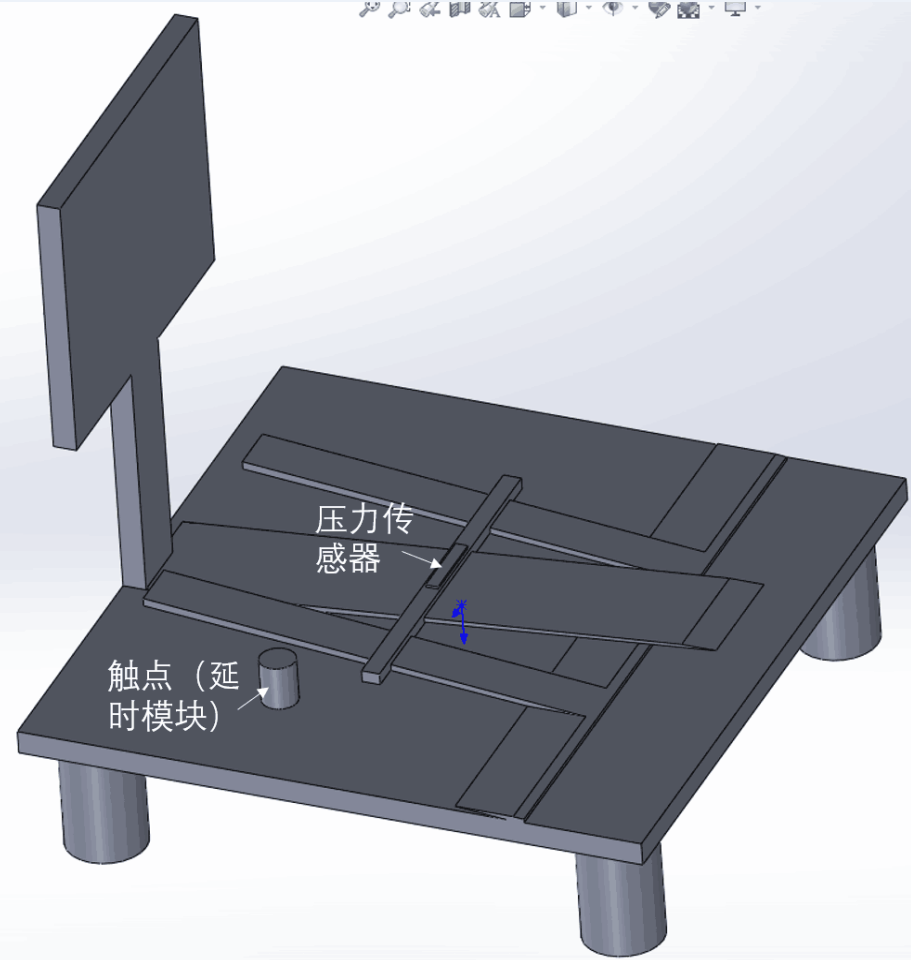
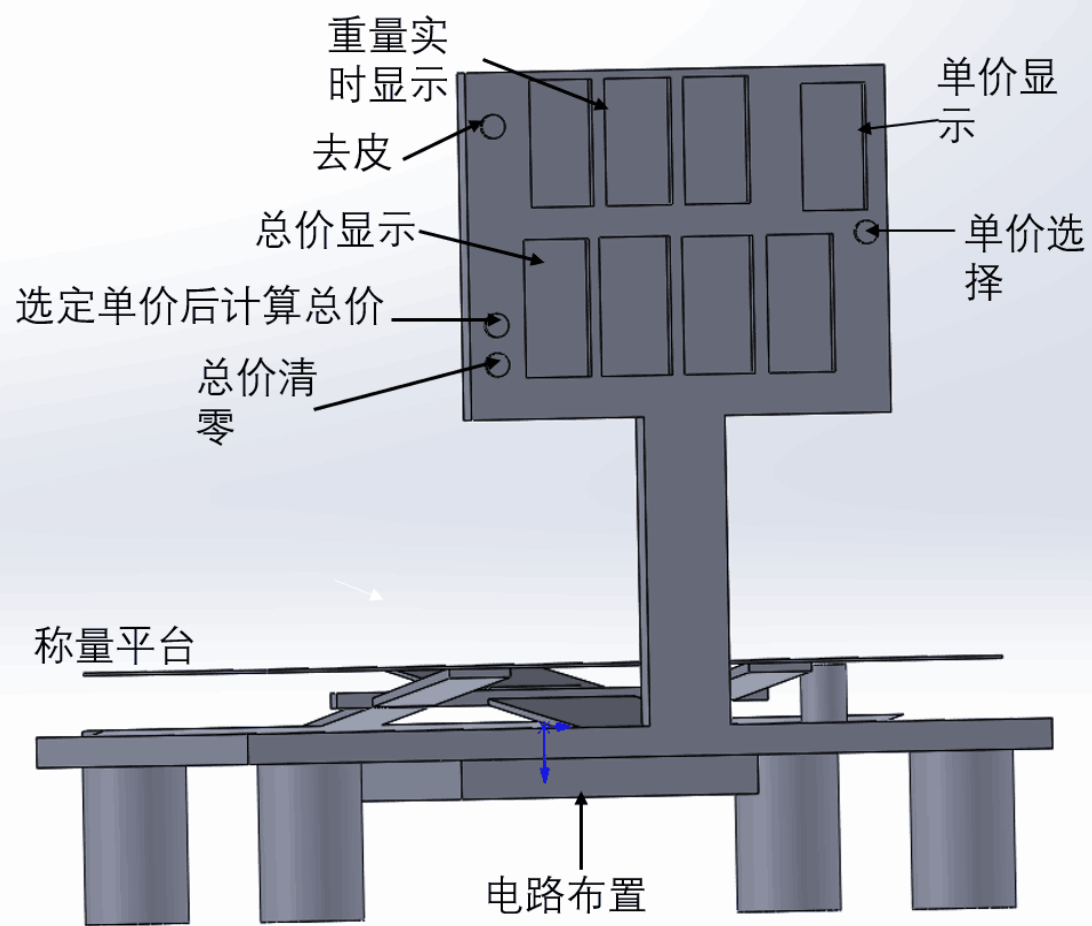

PART 02

流 程 图 及 电 路 设 计

流程图

电子秤整体流程

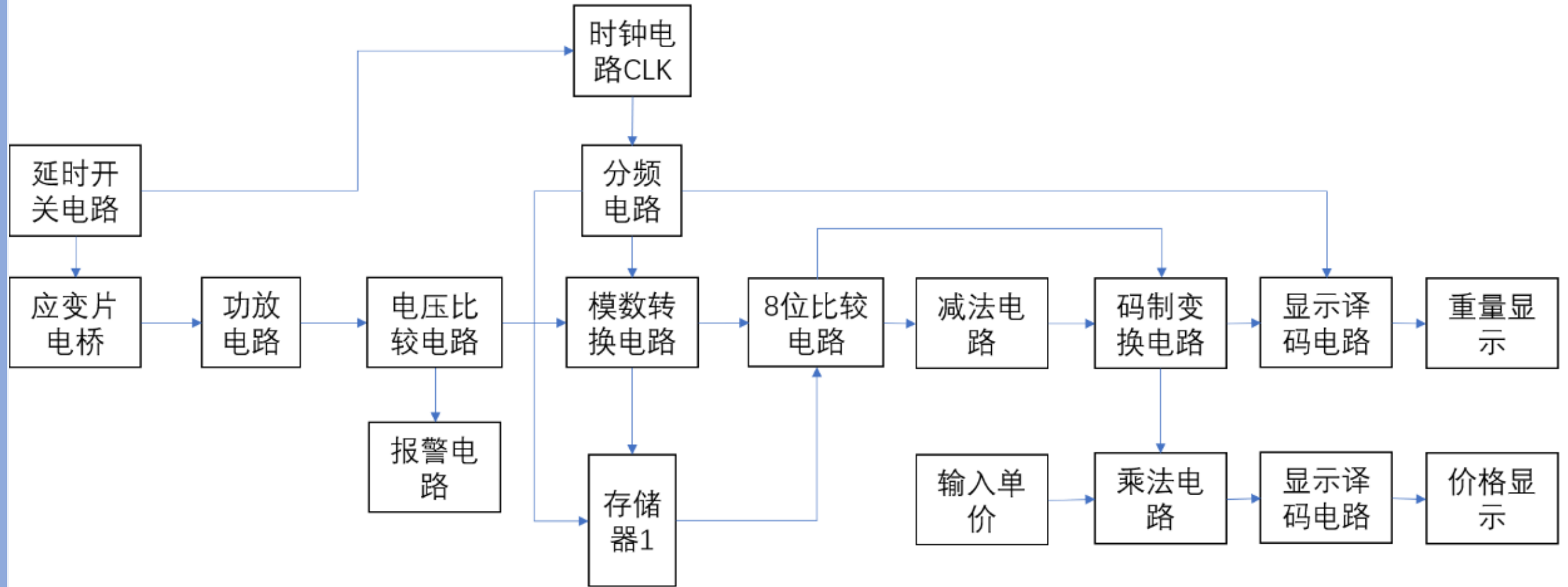

流程图

计价器乘法电路

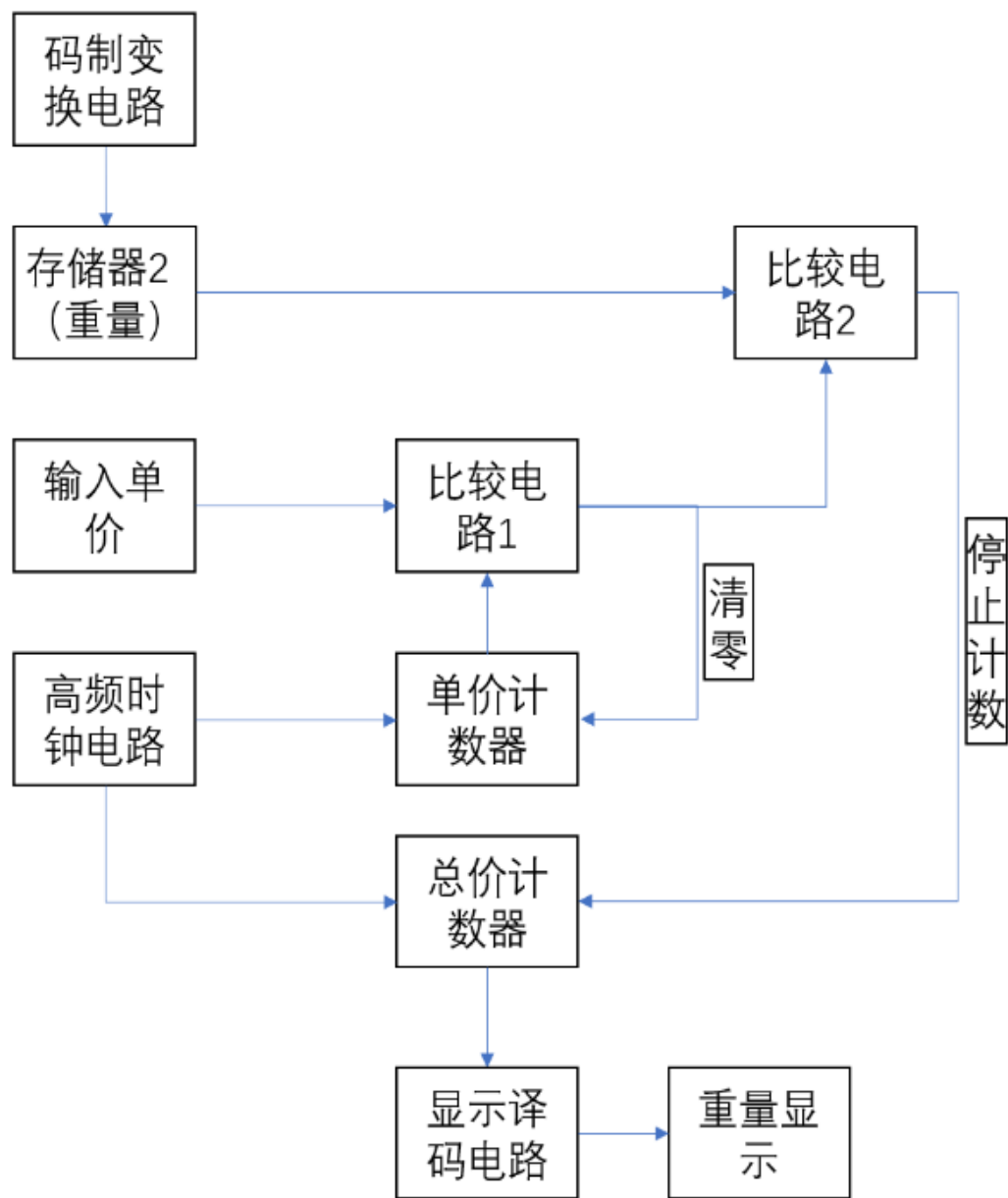

电路图设计

重量读取

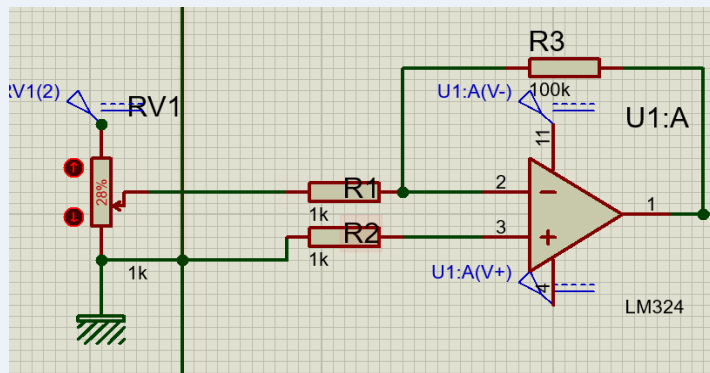

延时关机

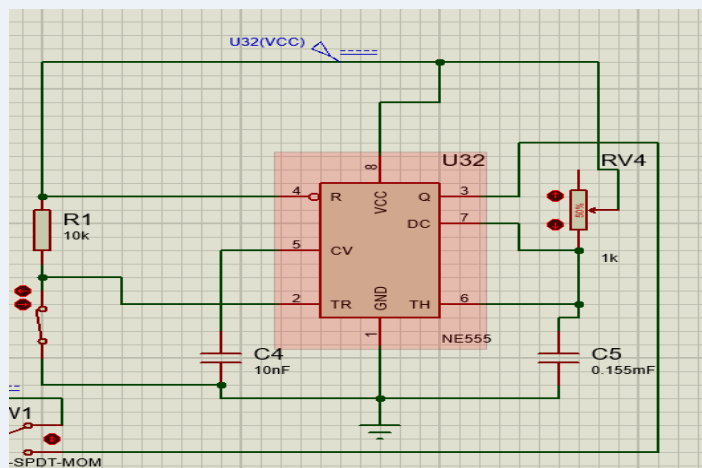

译码模块

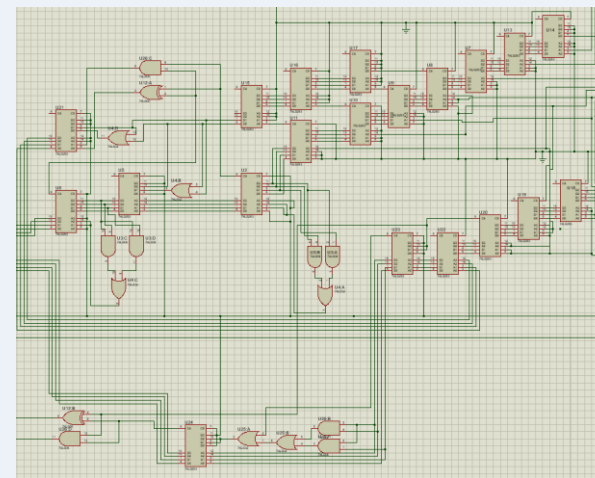

超重报警

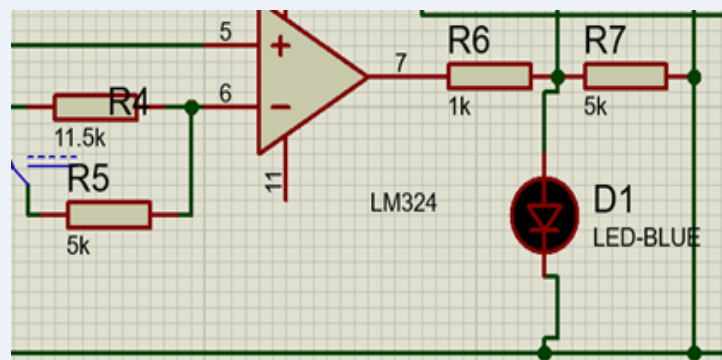

模数转换&码制转换

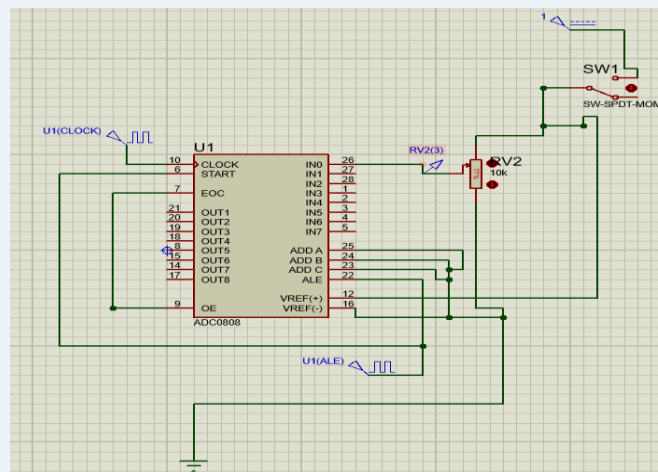

去皮计算

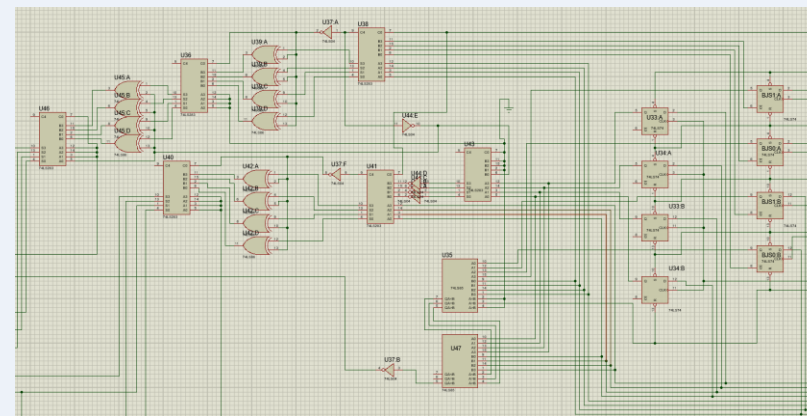

电路图设计

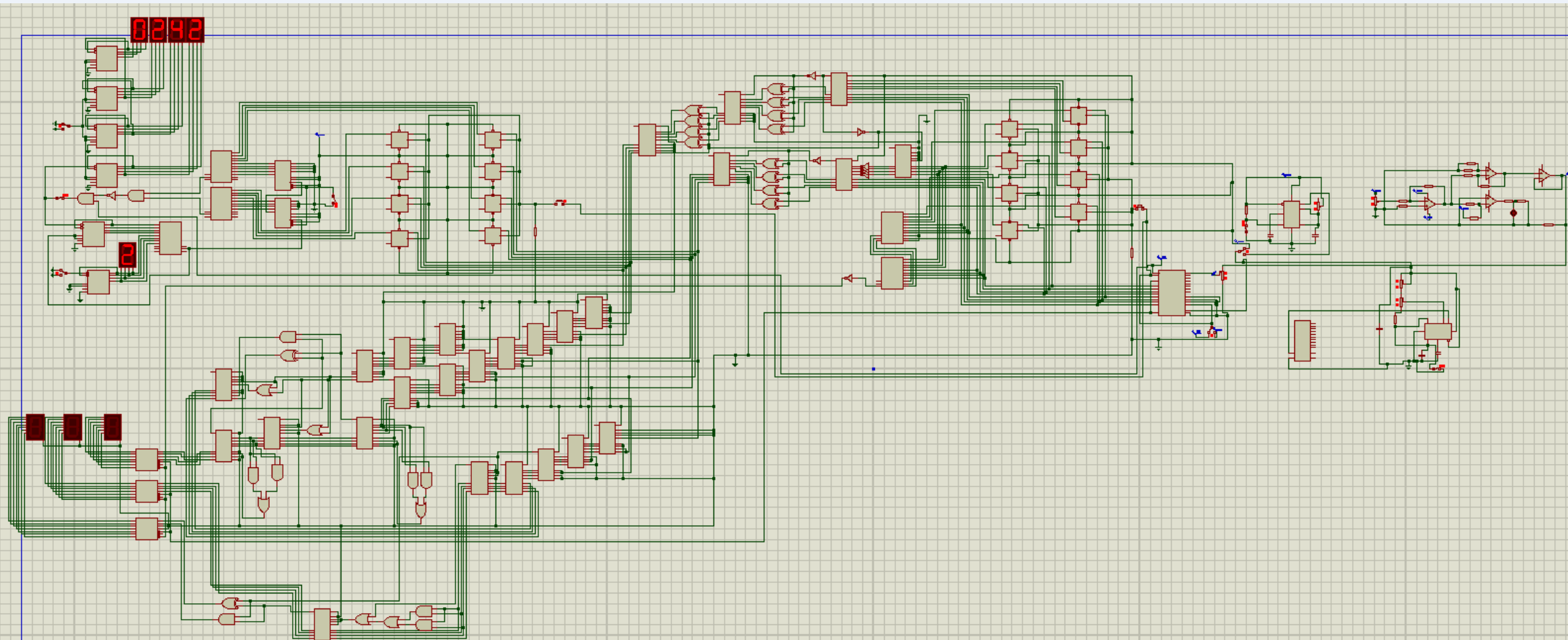

PCB设计(部分)

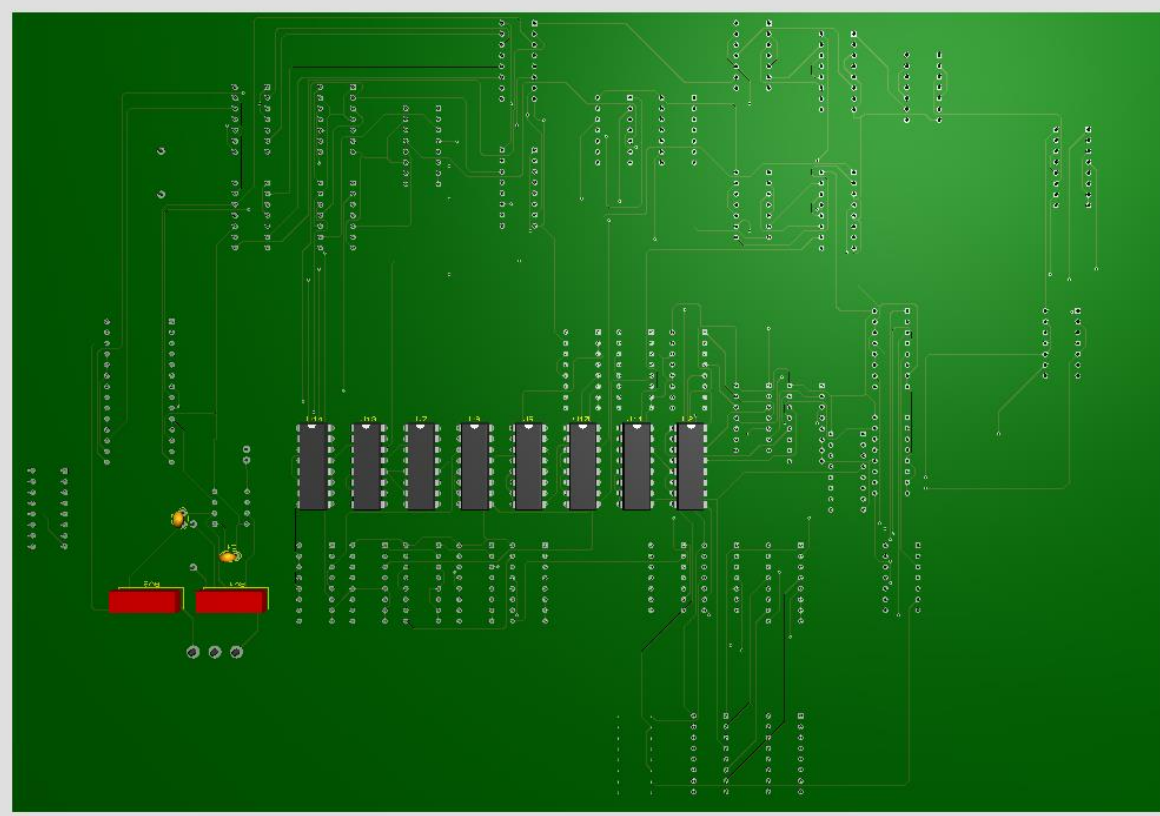
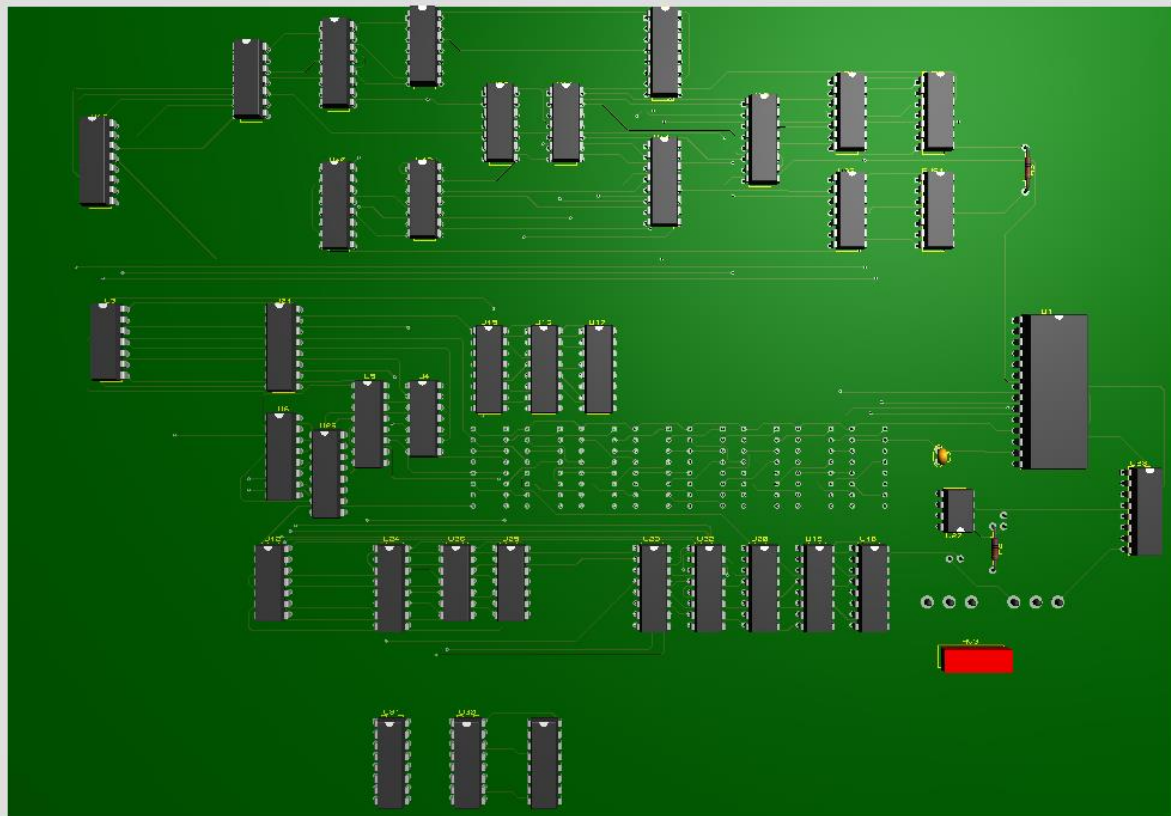

PART 03

Proteus模拟

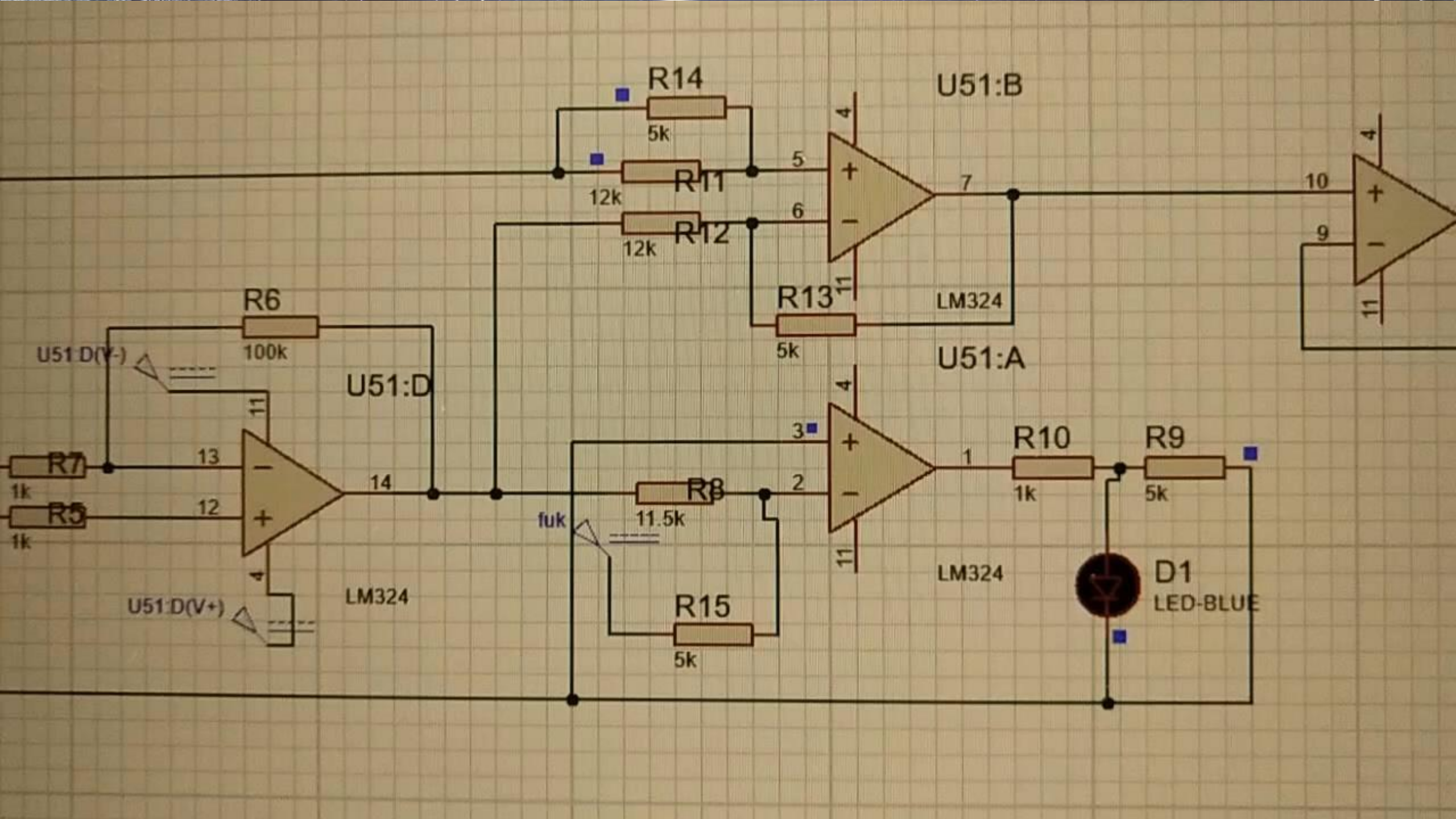

PART 04

电 路 组 装

延时关机模块

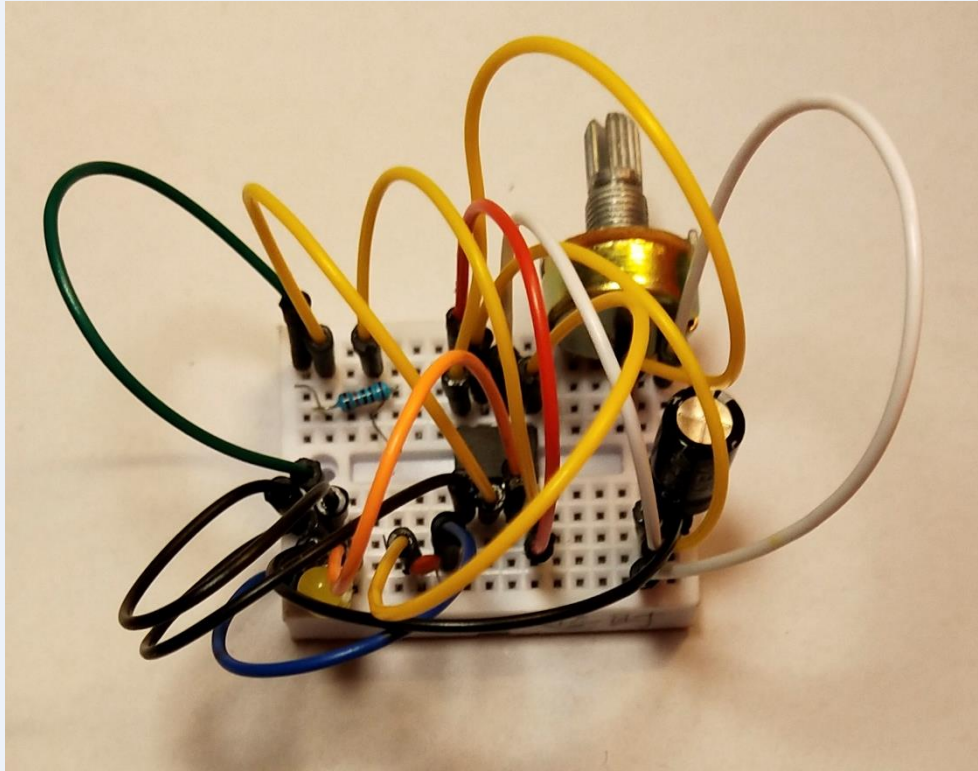

信号放大&超重报警

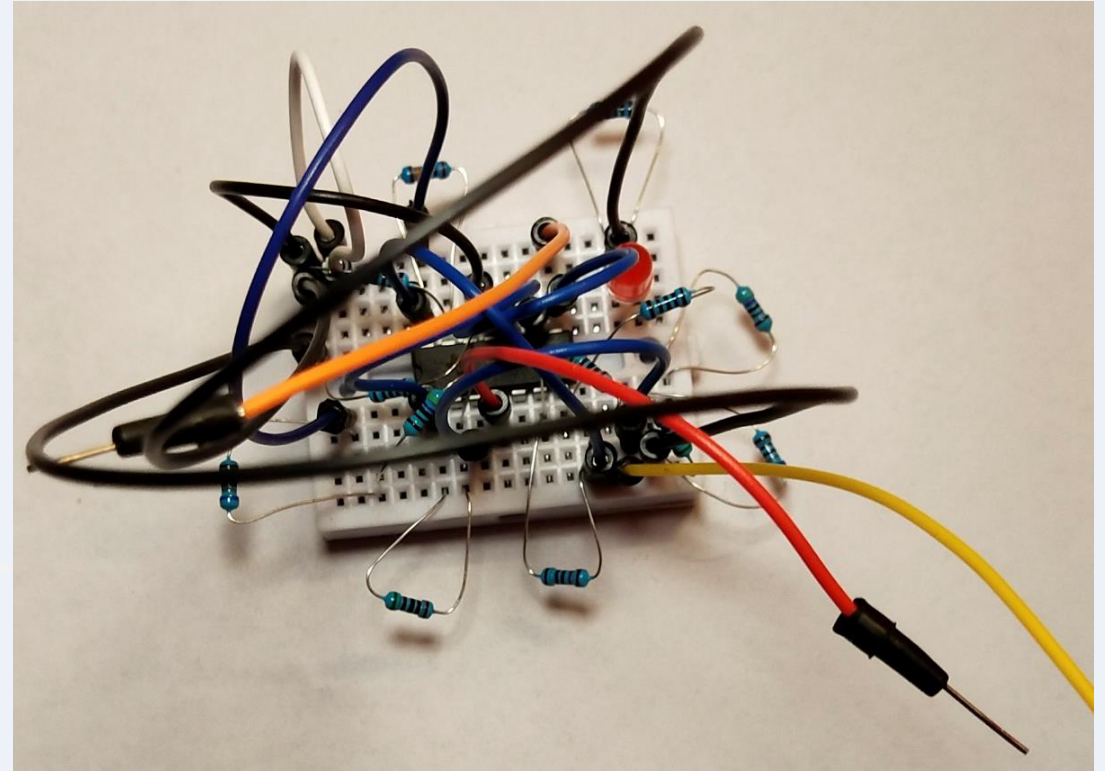

进制转换

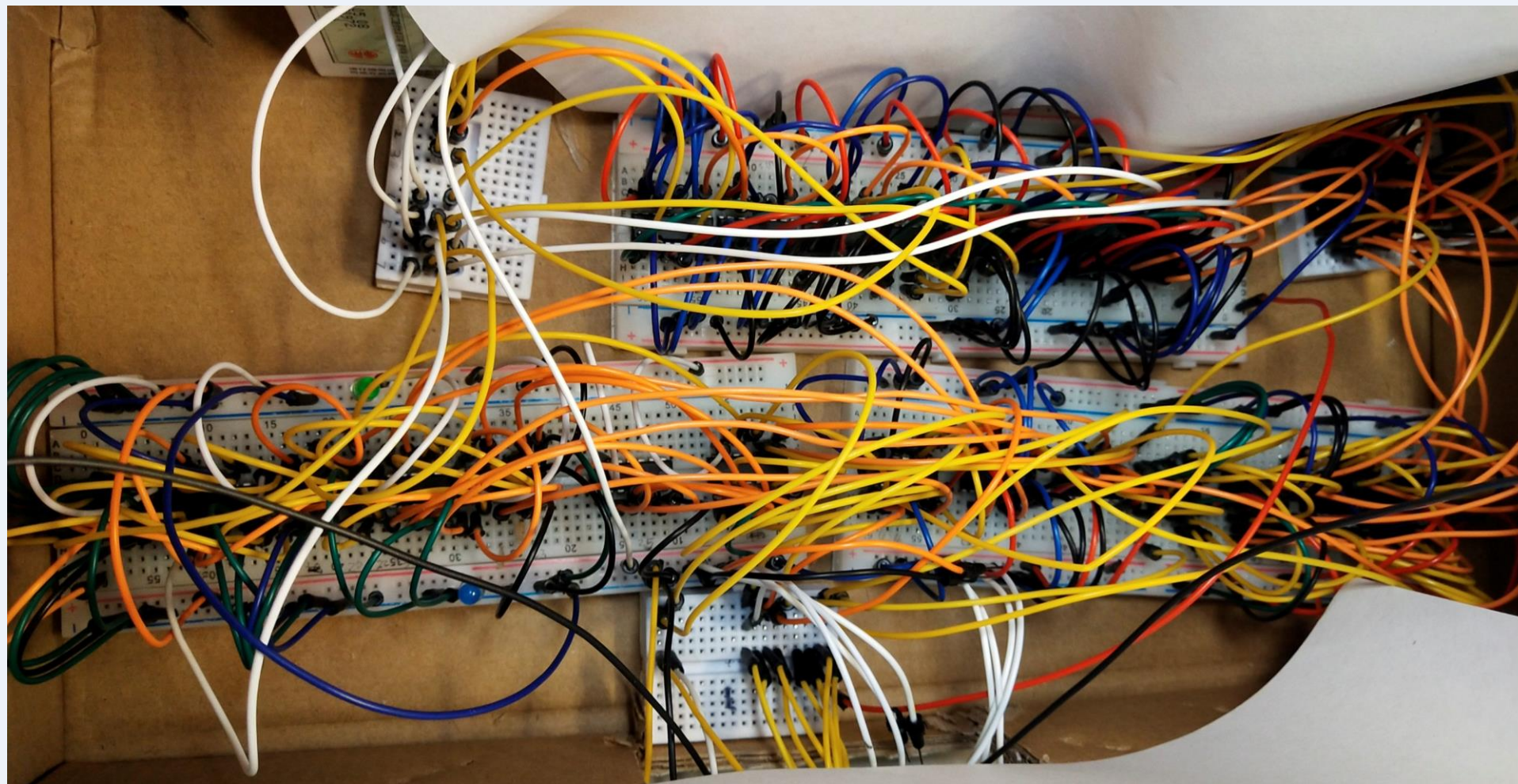

去皮电路

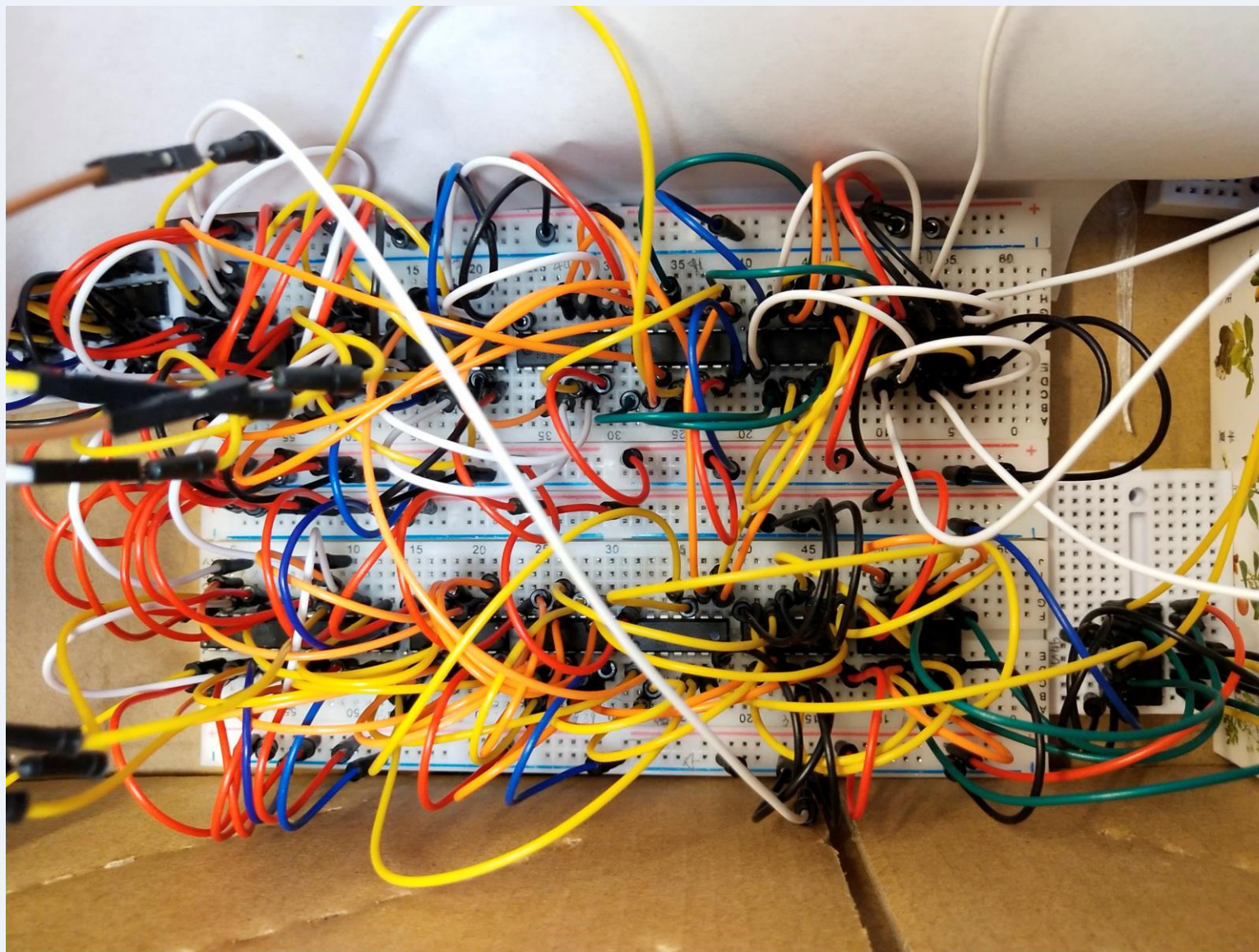

显示模块

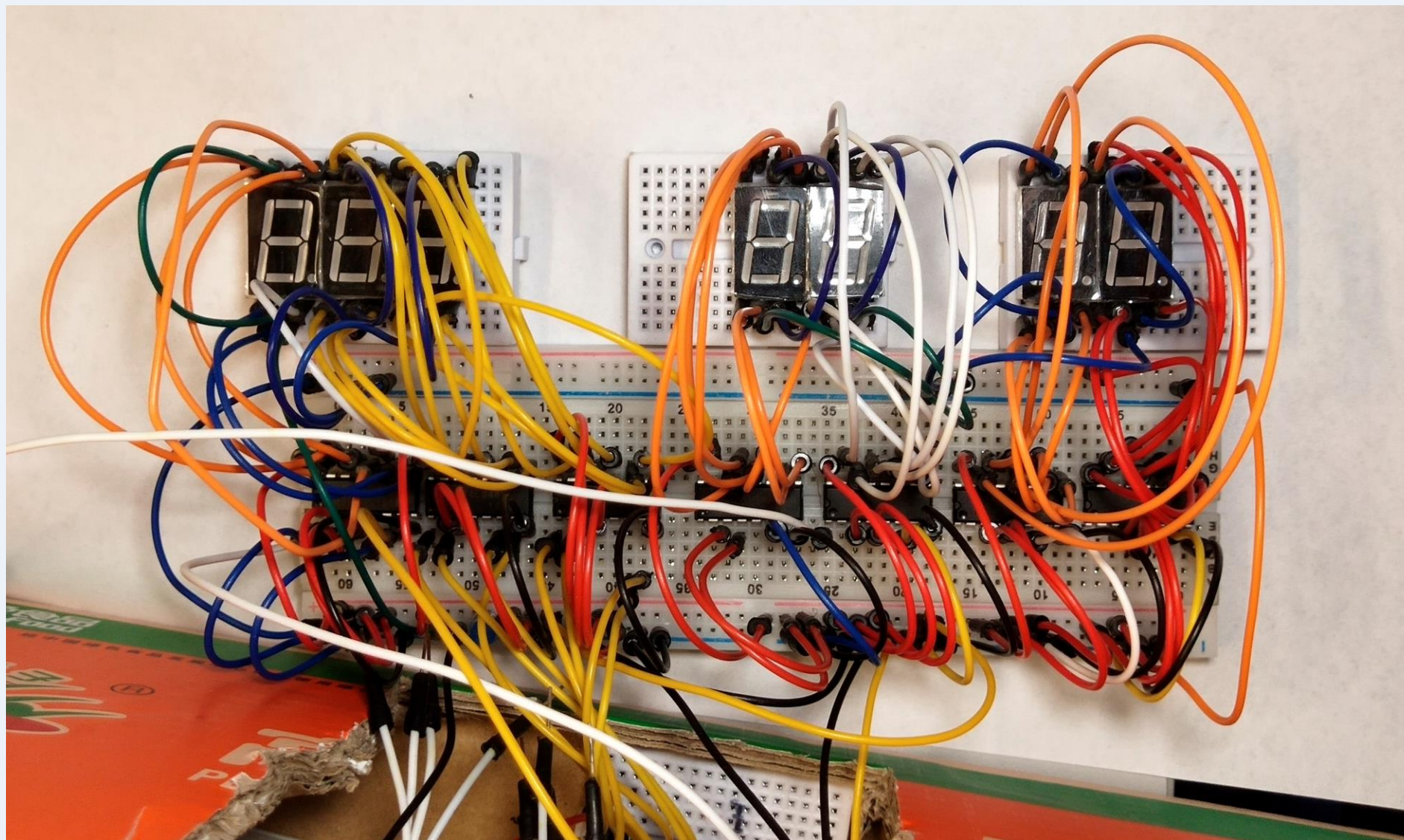

模数转换&时钟电路

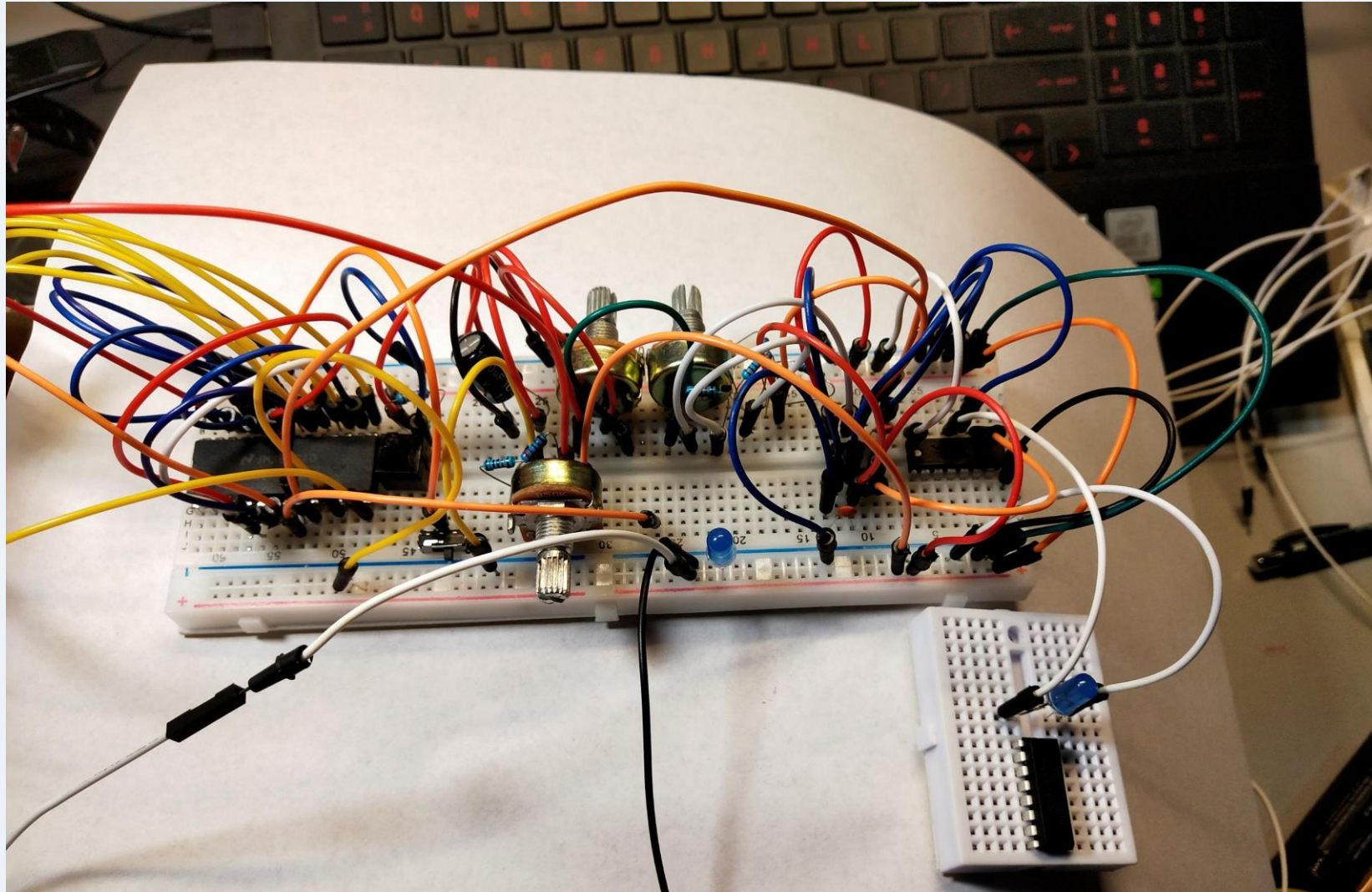

单价-总价计算

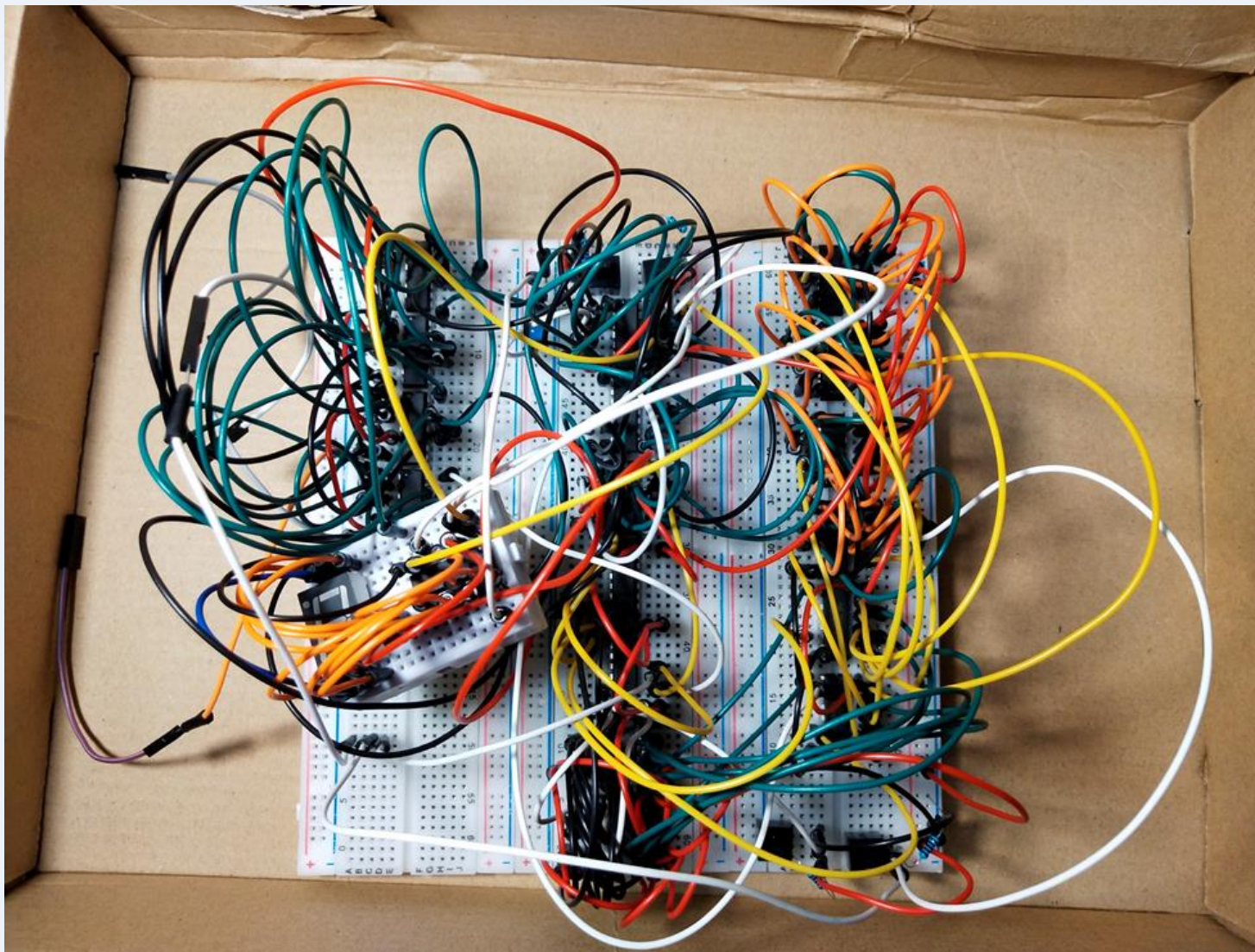

制作过程

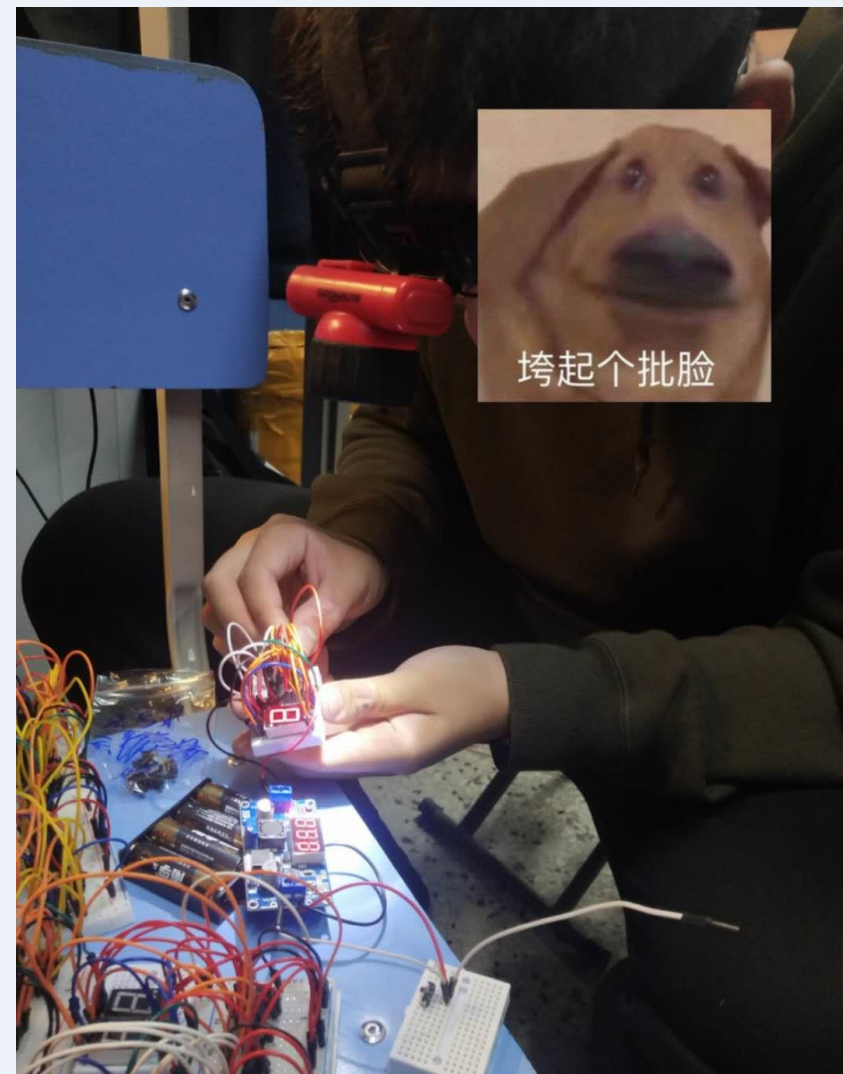
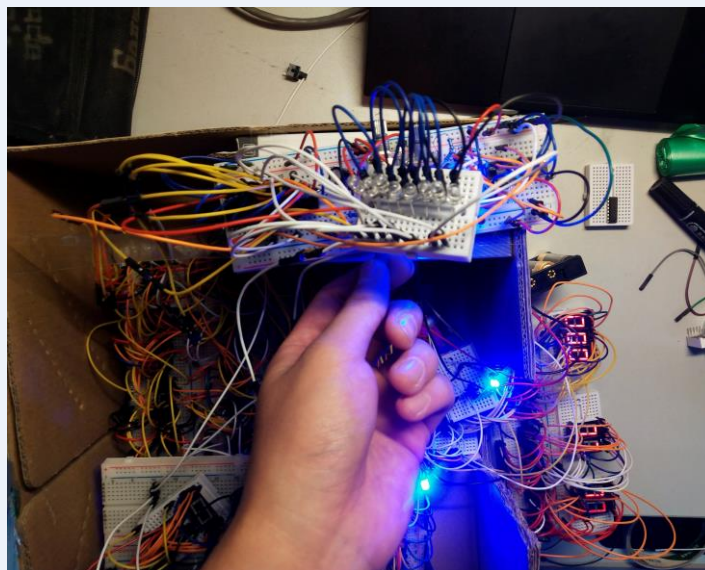
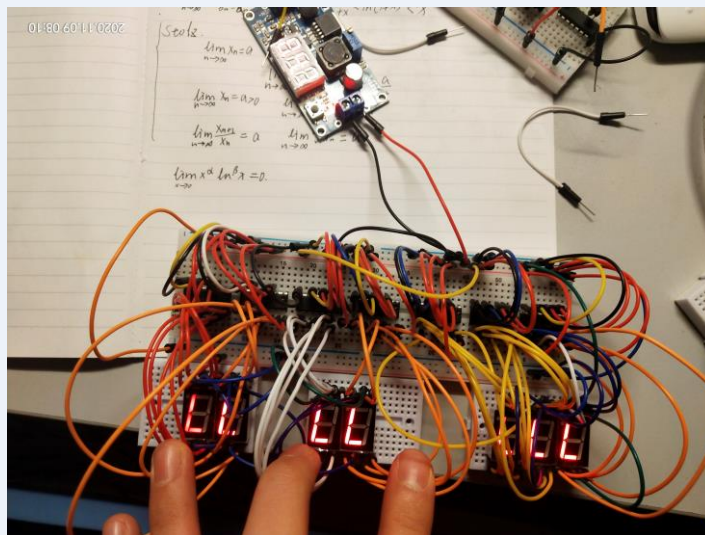

PART 05

实 际 电 路
测 试 调 试

重量显示测试

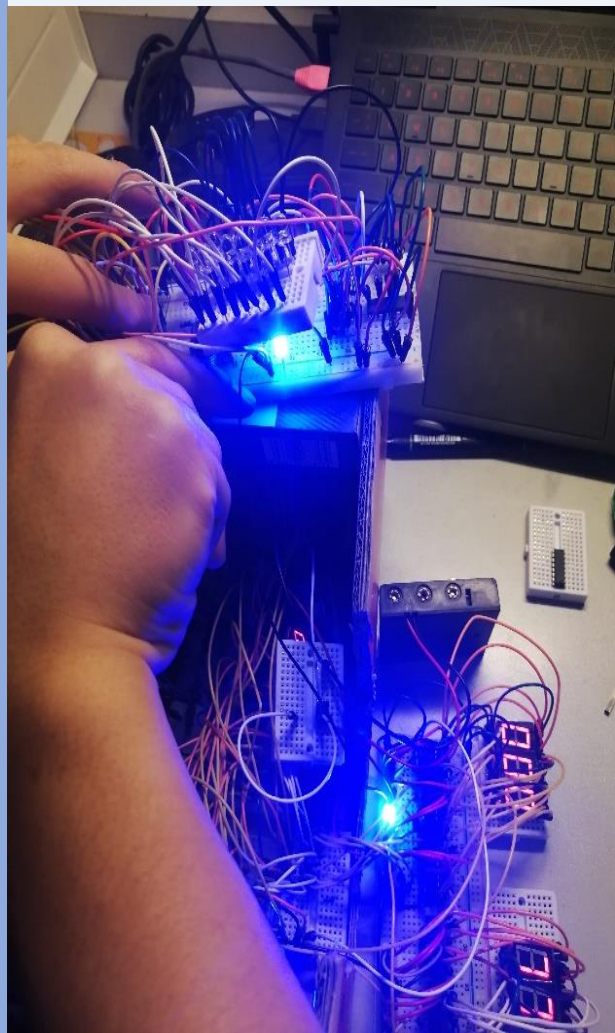

00000000

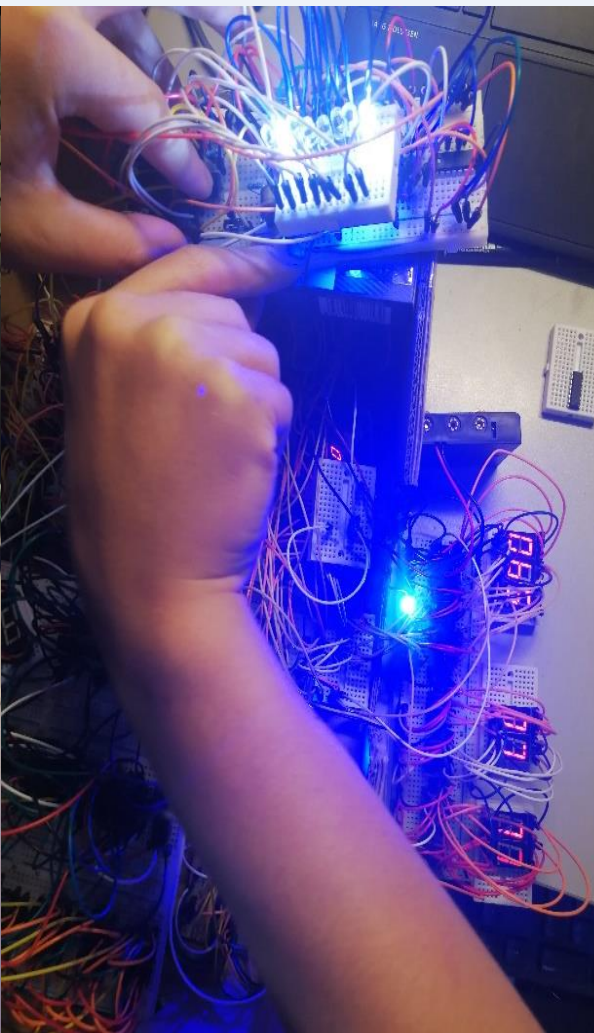

01000001

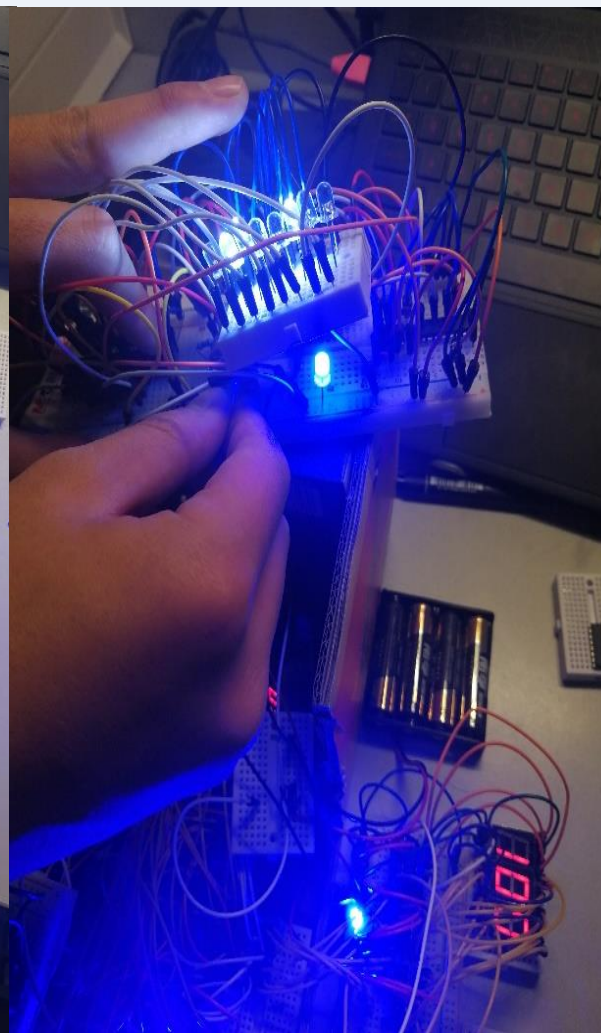

01100100

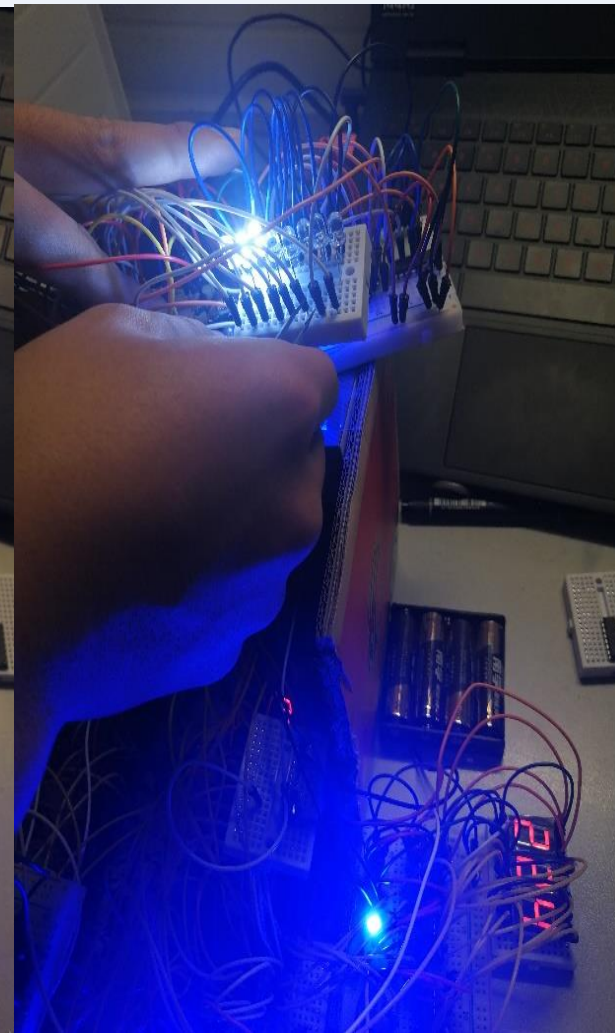

11100000

单价显示测试

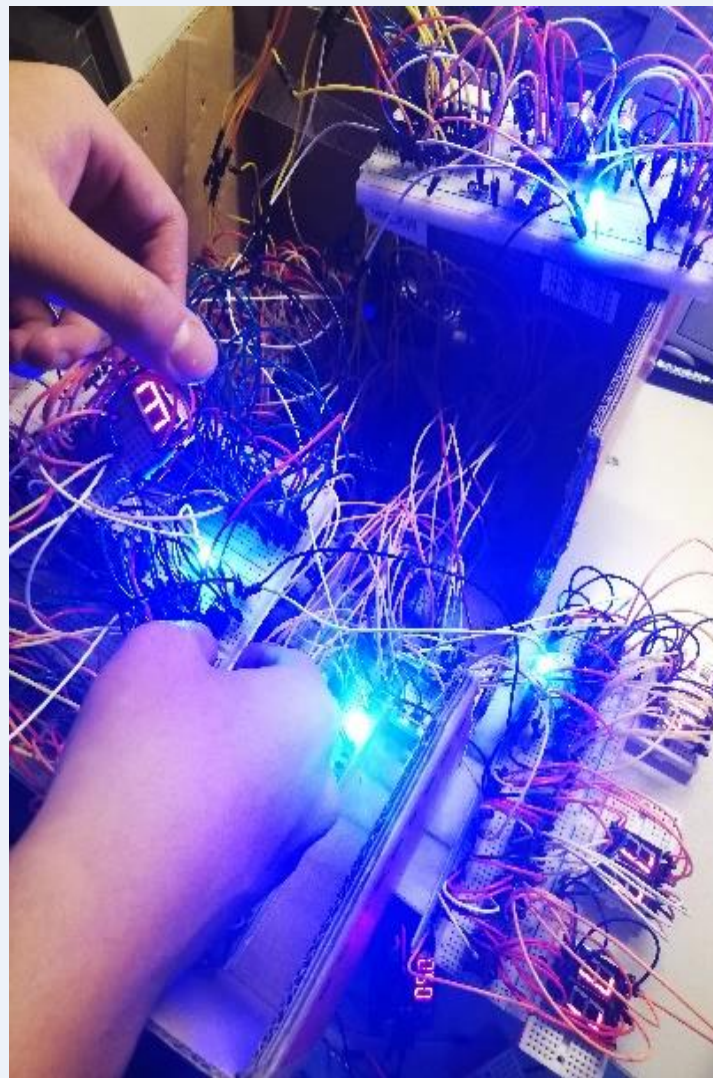

3

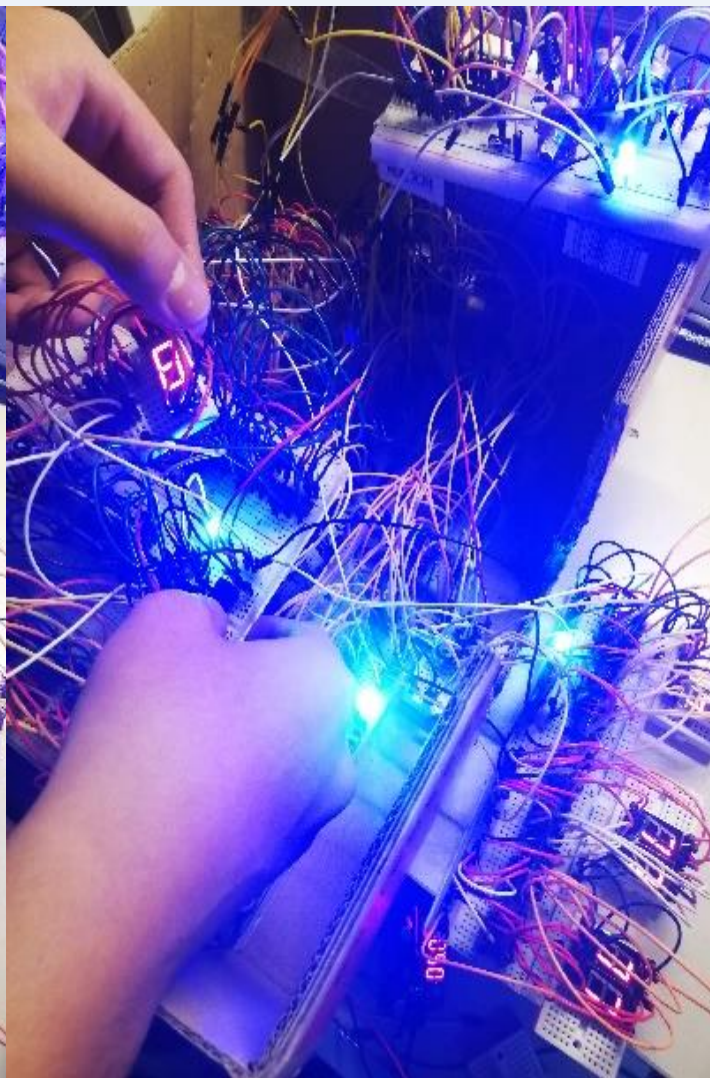

8

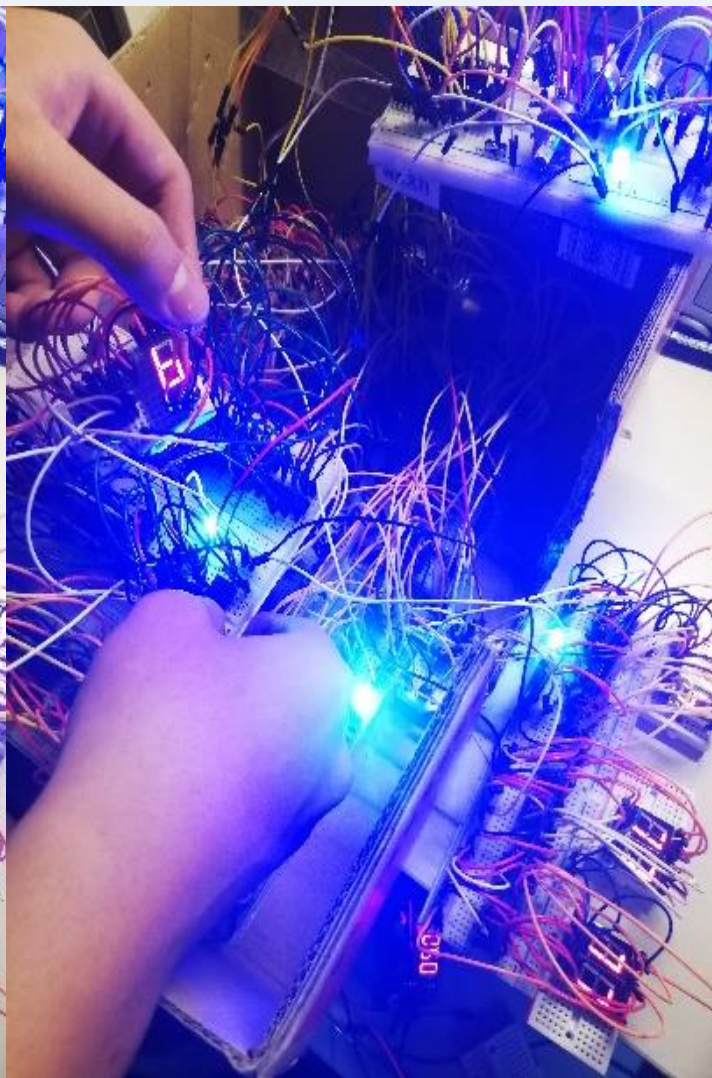

6

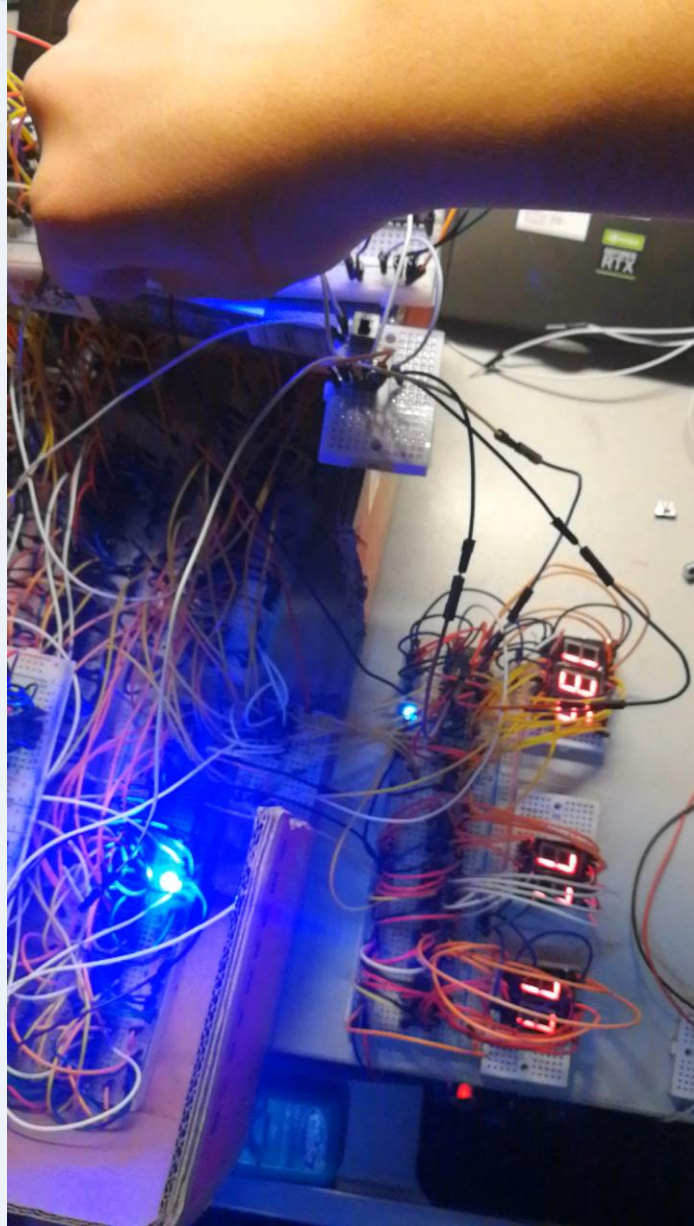

去皮测试

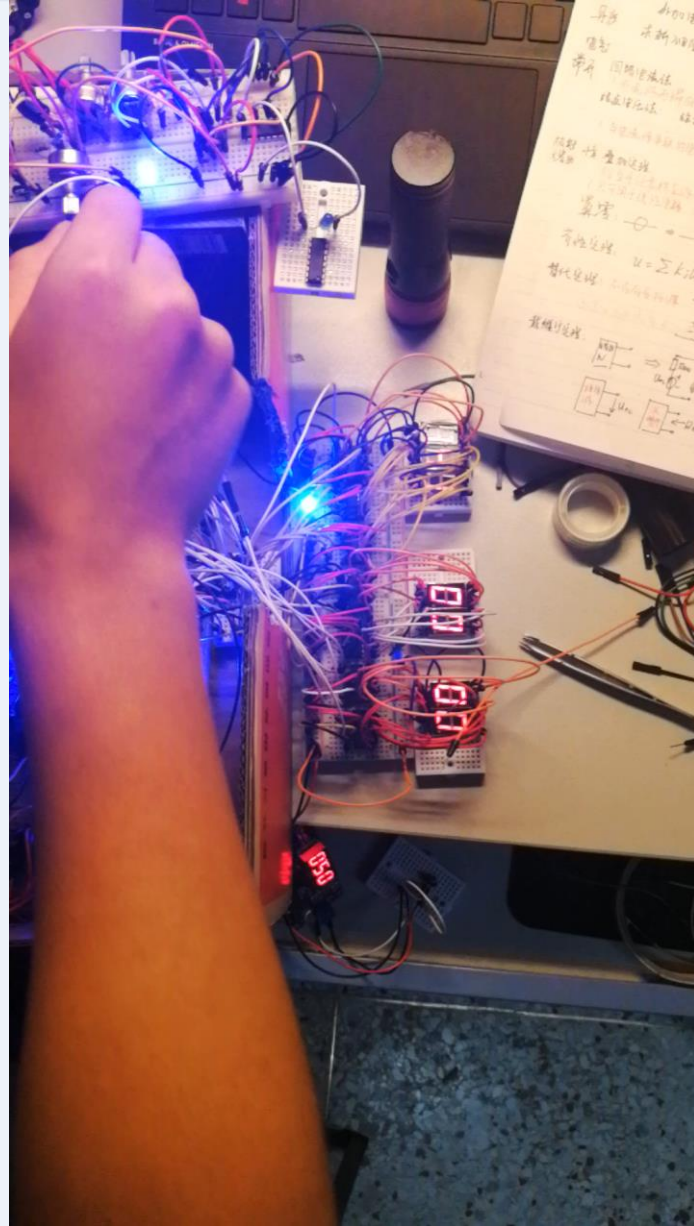

计价测试

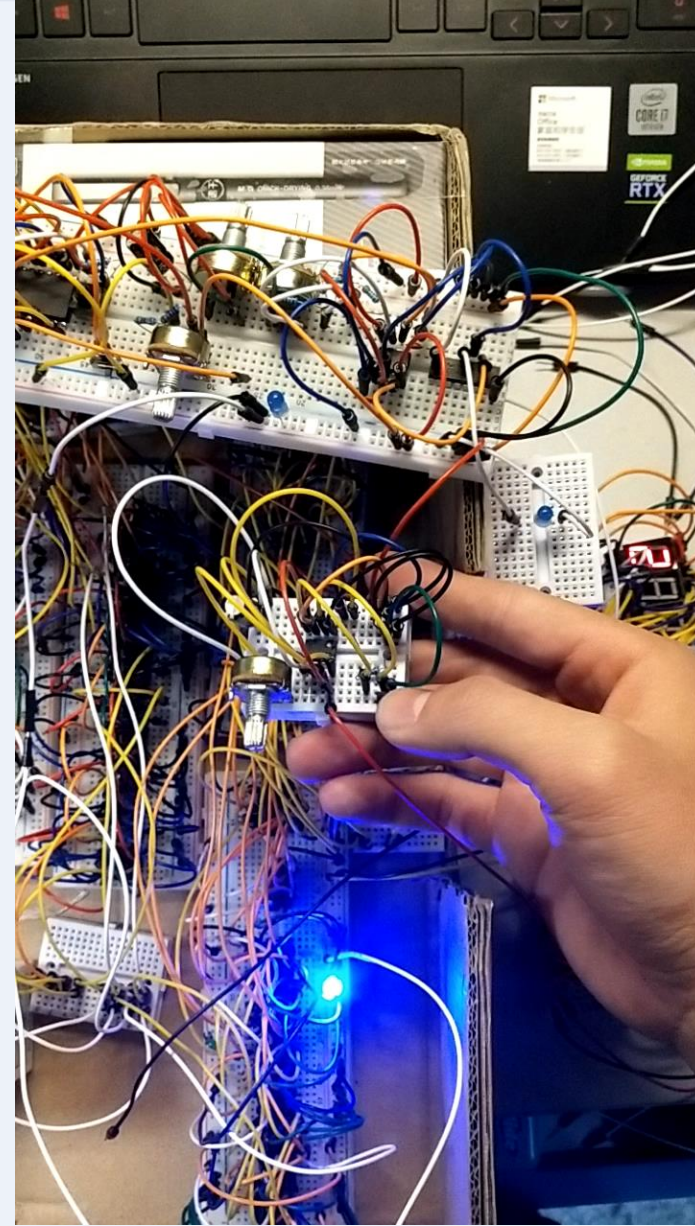

延时关机测试

感谢您的倾听！
